

STM Motorized Cisco WebEx Board 55" | Board Pro 55" display-specific, mobile lift system

Item no.: 5855

The STM Motorized Cisco WebEx Board 55" | Board Pro 55" is a mobile, height adjustable lift system, which has been specially designed for the Cisco WebEx Board 55" and Cisco WebEx Board Pro 55".

The hole pattern of the mobile lift system is designed for Cisco's collaboration room systems.

Locking screws on the screen mount secure the screen against unhooking and falling down.

The height of the screen can be adjusted electromotorically with a wired remote control. The stroke of 980 mm allows the screen height to be optimally adjusted for standing and seated viewers.

The lift system also features collision protection, which immediately stops the movement of the screen as soon as resistance is encountered.

Castors with locking brake provide mobility.

Cable management is neatly organized via a flexible cable drag chain.

The surfaces of the STM Motorized Cisco WebEx Board 55" | Board Pro 55" are finished with a solvent-free, impact- and scratch-resistant powder coating in black.

The maximum load capacity is 50 kg.



STM Motorized Cisco WebEx Board 55" | Board Pro 55" display-specific, mobile lift system

Item no.: 5855

- Mobile lift system
- Display-specific for Cisco WebEx Board 55" and Cisco WebEx Board Pro 55" collaboration room systems
- Hole pattern optimised for Cisco WebEx Board 55" and Cisco WebEx Board Pro 55"
- Electro-motorized height adjustment with 978 mm stroke
- Wired remote control
- Collision prevention - lift stops if there is resistance
- Cable management via cable drag chain
- Lockable media cabinet, incl. multiple plug and shelf for mini-PC, e.g.: Intel NUC
- Castors with locking brake
- Dimensions: W 1202 x D 794 mm
- Safety screws - secure the screen against unhooking and falling down
- 50 kg max. load
- Solvent-free, impact- and scratch-resistant powder coating in black

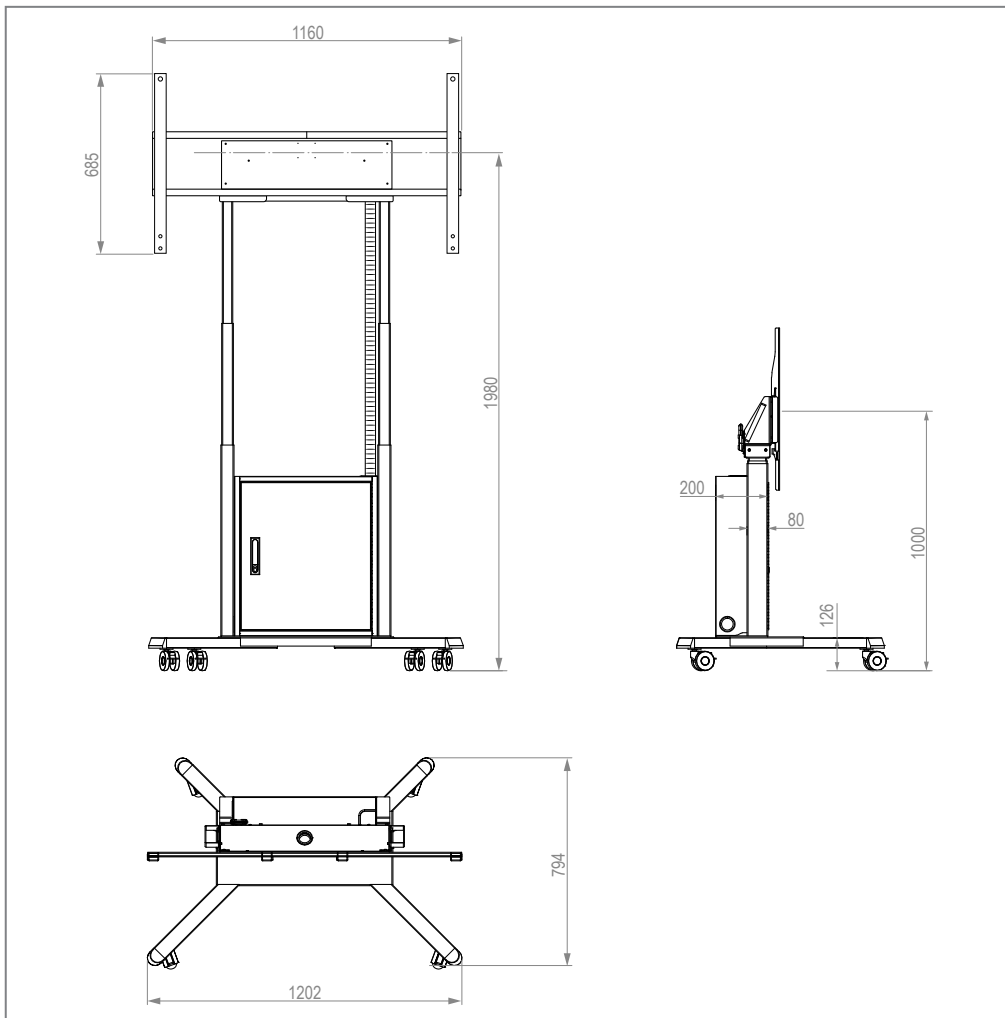

Lockable media cabinet



Hole pattern display-specific optimised



Cable management via cable drag chain

Technical changes reserved | This document is the property of HAGOR Products GmbH. Forwarding and duplication of this document, utilization and communication of its contents are not permitted unless expressly permitted. A violation obliges you to pay compensation. All rights reserved in the event of a patent, utility model or design registration.